

INFLUENCES DE LA VERTICALE ET DE L'HORIZONTALE SUR LE POSITIONNEMENT
D'UN VISAGE.

LA TÊTE 1

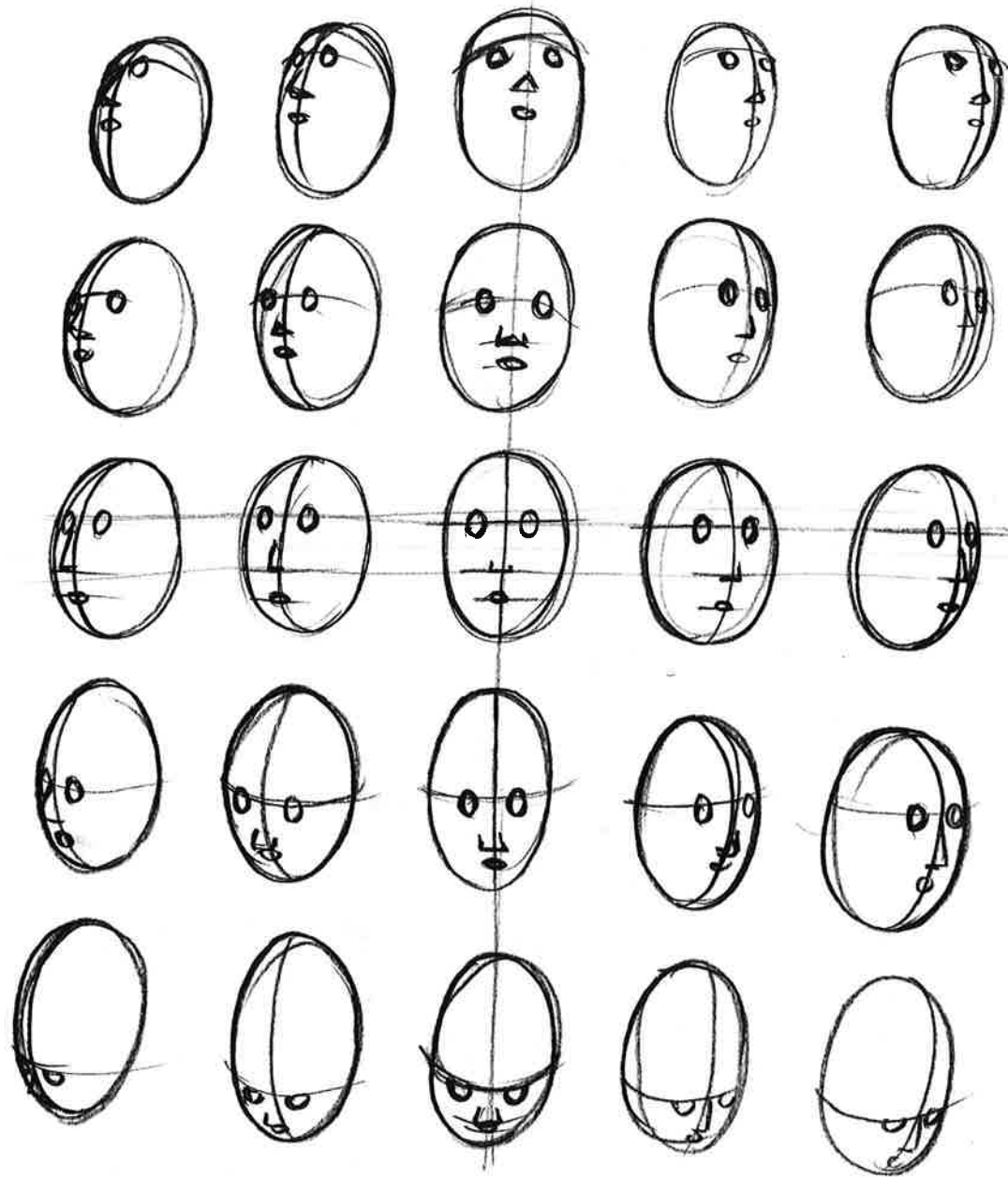

LA TÊTE 2

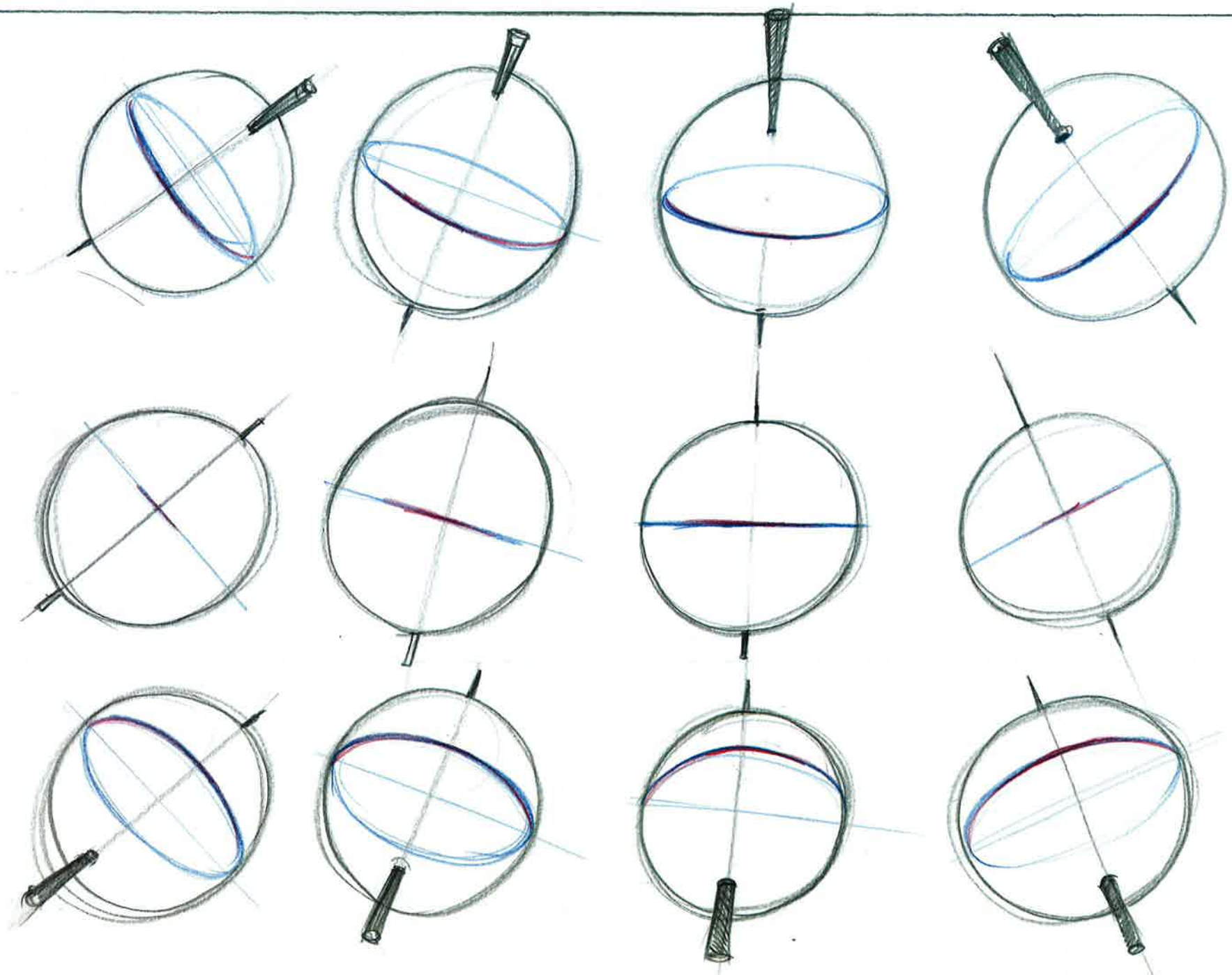

EXERCICE DE VISUALISATION SPATIALE 4

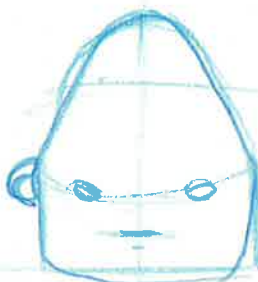
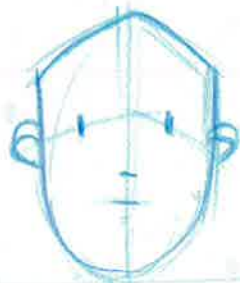
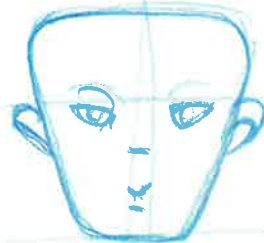
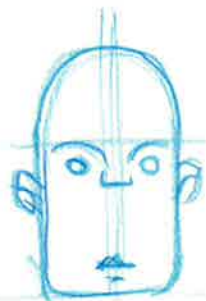
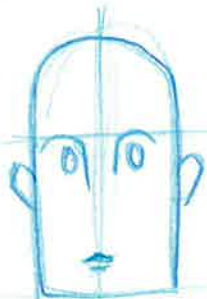
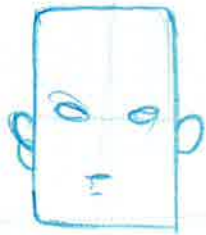
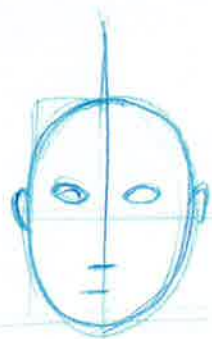

IL FAUT S'AMUSER SANS AUCUNE LIMITE ... ALLER TROP LOIN POUR CONNAITRE CELLES-CI.

JOUER AVEC LES FORMES ; LA PAREÏDOUÏE

LA TÊTE 3

ETAPES DE LA STRUCTURE D'UN
VISAGE DE FACE 1

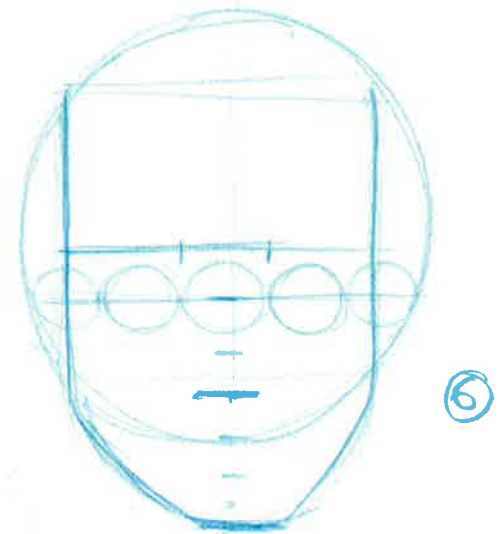
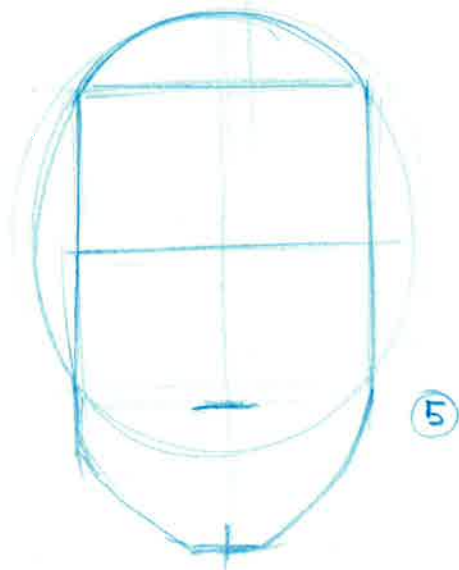
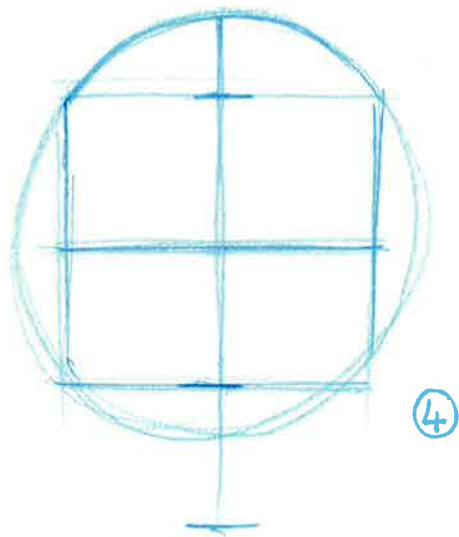
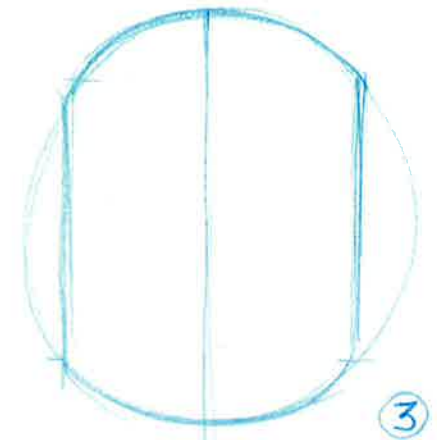
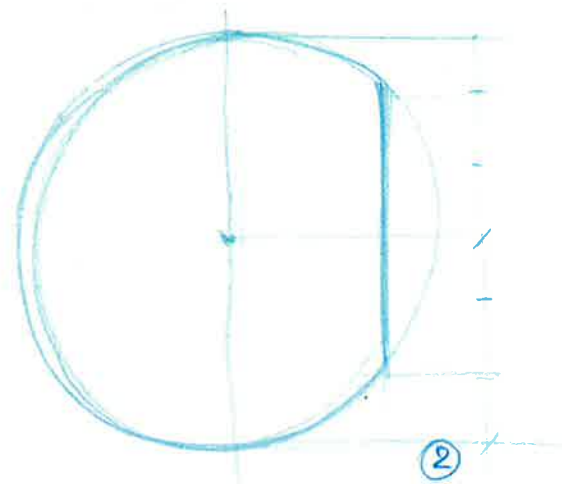
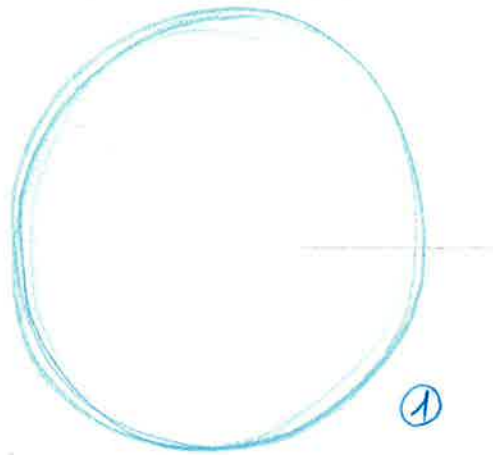

ÉTAPES DE LA STRUCTURE D'UN
VISAGE DE FACE 2

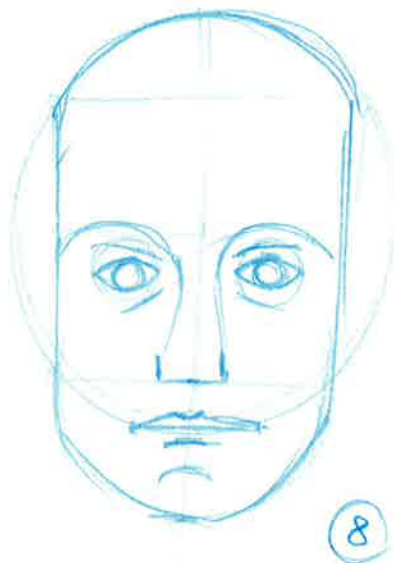
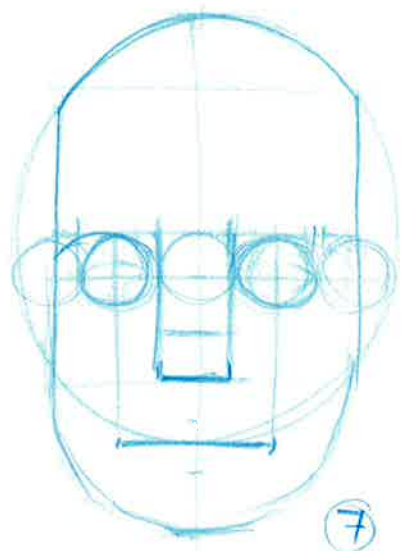

CONSTRUCTION FACE 2

ÉTAPES DE LA STRUCTURE D'UN
VISAGE DE PROFIL ①

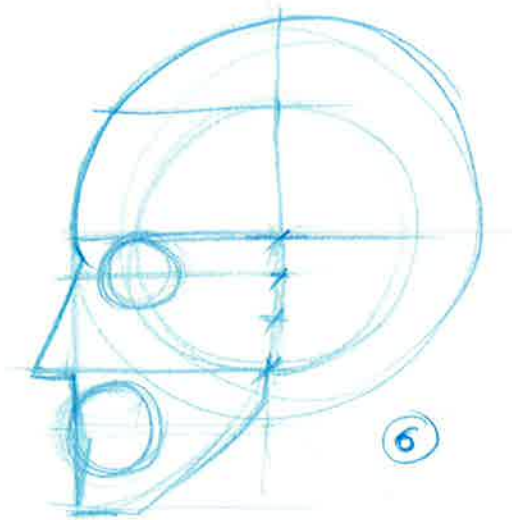
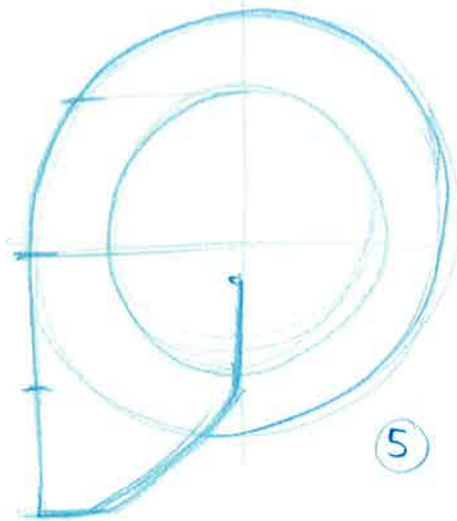
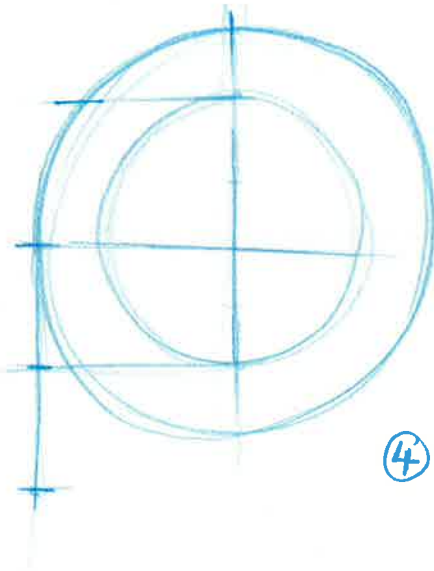
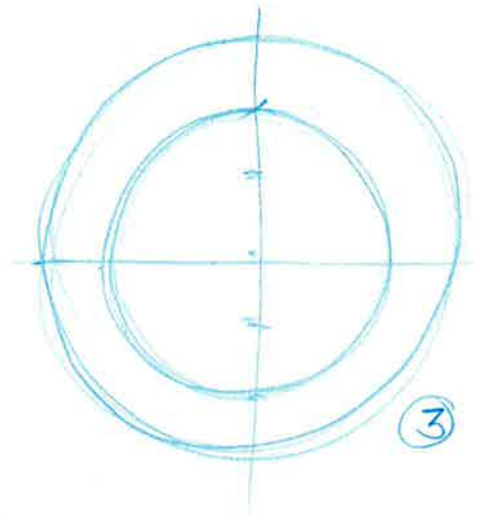
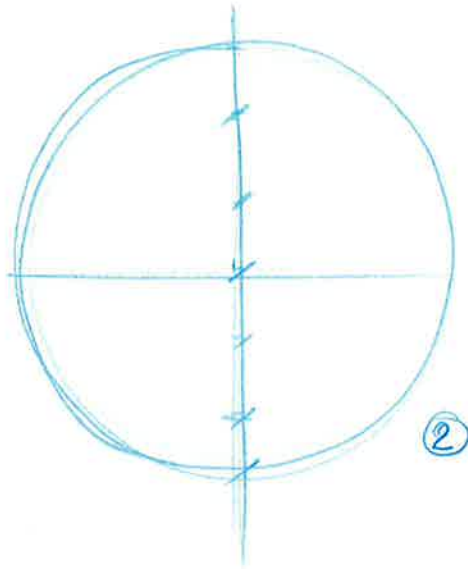
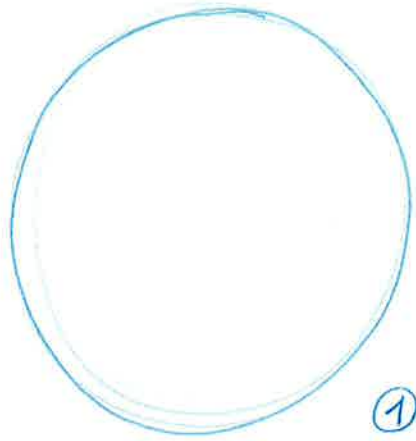

CONSTRUCTION PROFIL 1

ÉTAPES DE LA STRUCTURE D'UN
VISAGE DE PROFIL (2)

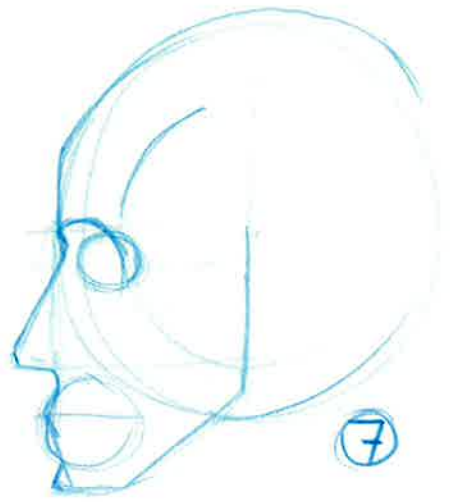

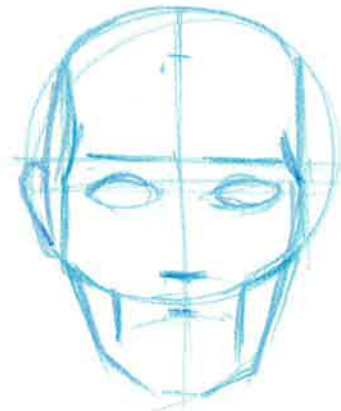
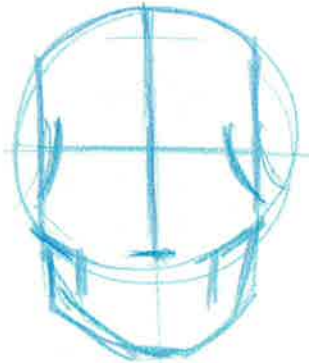
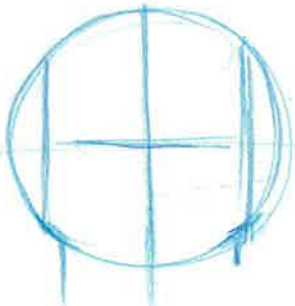
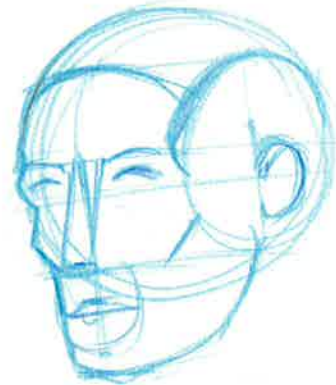
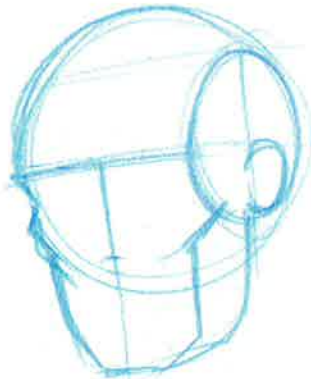
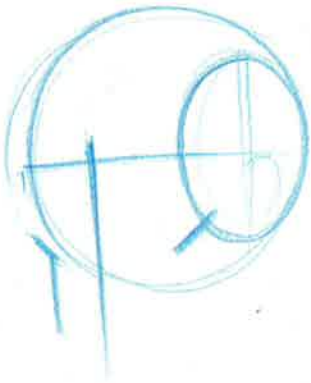
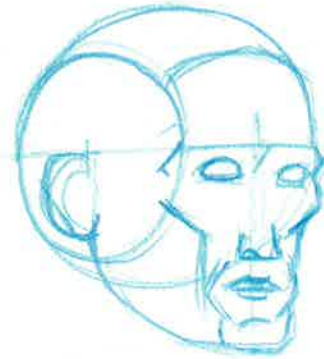
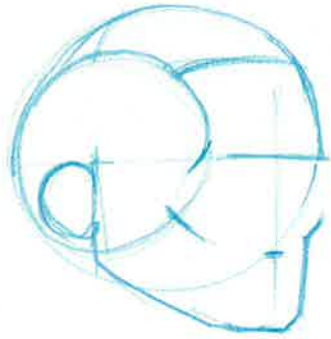
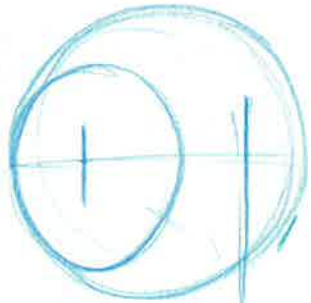

FAITES LA MÊME
CHOSE DANS TOUTES
LES DIRECTIONS.

EYE:

CONSTRUCTION 3

LE CRISTALLIN: OBSERVEZ QU'IL EST BOMBÉ!

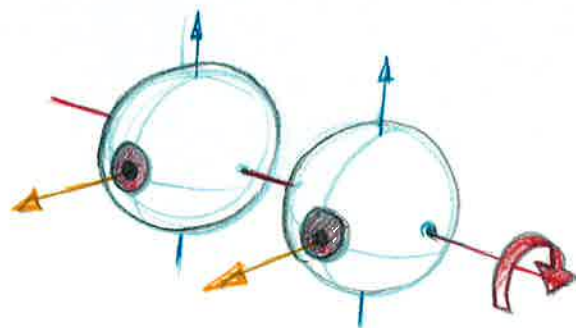
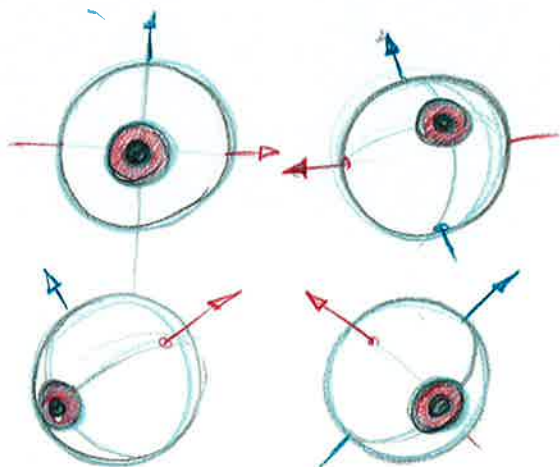

⚠ LES YEUX BOUGENT EN MÊME TEMPS.

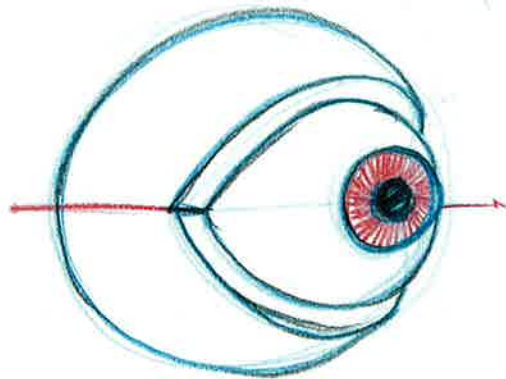
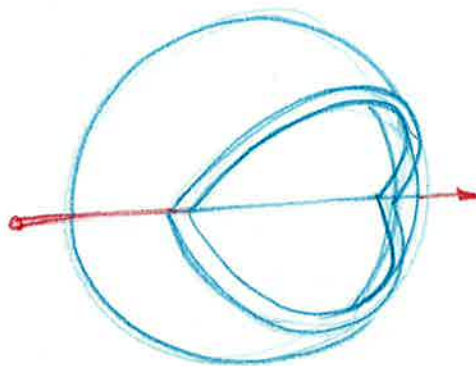
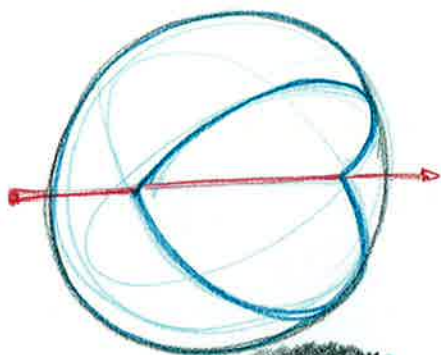
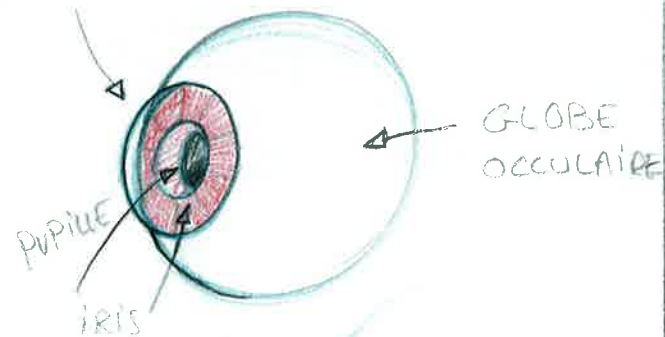

LES PAUPIÈRES:
UNE SPHÈRE COUPÉE D'UN QUARTIER, ENCLOUBANT
UNE SPHÈRE PLUS PETITE.

L'OEIL 1

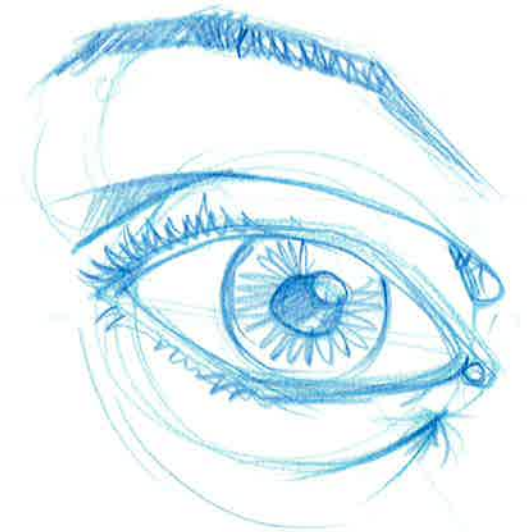
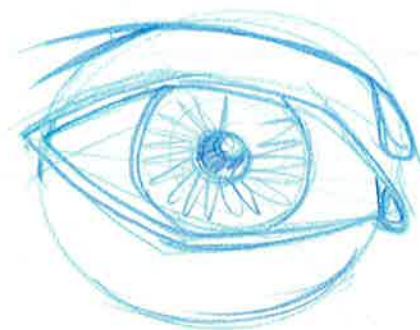
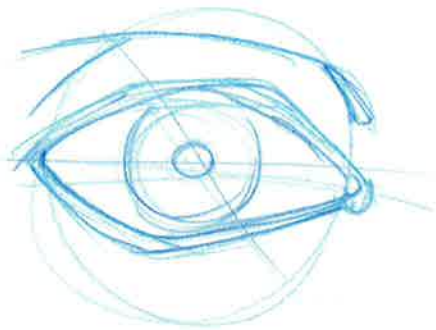
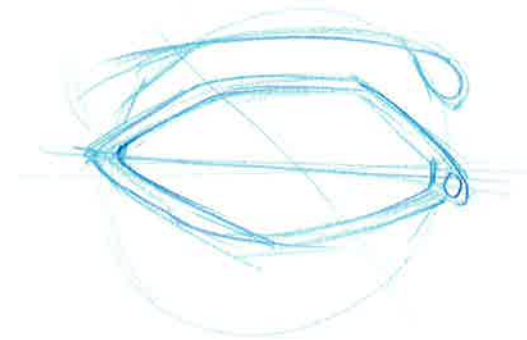
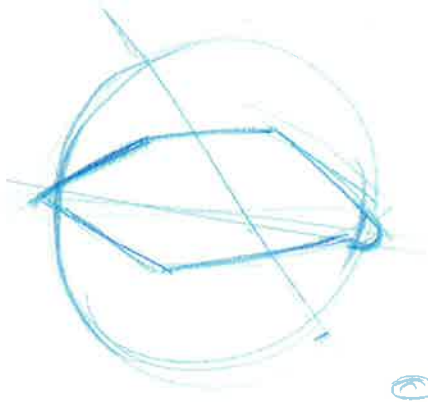
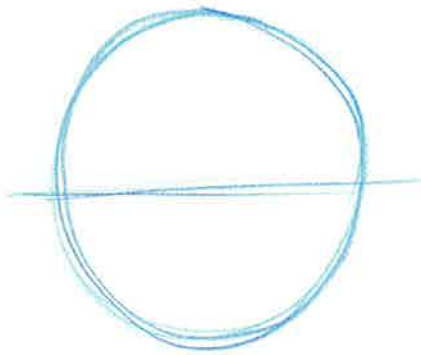

ÉTAPES POUR STRUCTURER
UN OEIL

L'OEIL 2